



17716 48<sup>th</sup> Drive NE  
ARLINGTON, WASHINGTON 98223  
FAA-PMA FACILITY #PQ0111NM

# Service Bulletin Fuel Systems

Bulletin No.: PRS-110

Revision: 3

Date: 12-13-2022

**SUBJECT: Availability of idle and mixture control valve kits for RSA-5 and RSA-10 fuel injection servos.**

REVISION 2: Provides additional servo applications and patent number.

REVISION 3: Added servo applications.

**A. APPLICABILITY:**

This service bulletin applies to various RSA-5 and RSA-10 fuel injection servo part numbers which are presented in the table at the end of this document.

**NOTE: WHILE OTHER SERVOS MAY APPEAR EXTERNALLY SIMILAR TO PRECISION AIRMOTIVE MANUFACTURED UNITS, THE PARTS REFERENCED HEREIN ARE ONLY APPLICABLE TO SERVOS MANUFACTURED BY PRECISION AIRMOTIVE OR ITS PREDECESSOR IN INTEREST BENDIX. THIS BULLETIN DOES NOT APPLY TO ANY FUEL INJECTION SERVO MADE BY ANY OTHER MANUFACTURER.**

**B. COMPLIANCE:**

During overhaul or at any time early style idle or mixture valve lever assemblies are removed from a servo, install valve Kit P/N 2576659 in accordance with the following instructions and the current applicable Precision Airmotive component maintenance manual (CMM).



Early Style Idle Valve Lever Assy.



New Idle Valve Lever Assy. Parts

Early Style Idle Valve Lever Assy. Parts		New Idle Valve Lever Assy. Parts	
Part Number	Description	Part Number	Description
367757	Thrust Washer	2577321	Ball Race (2ea)
		2577319	Roller Assembly
2526408	Bushing	2577316	Bushing



Early Style Mixture Valve Lever Assy.



New Mixture Valve Lever Assy. Parts

Early Style Mixture Valve Lever Assy. Parts		New Mixture Valve Lever Assy. Parts	
Part Number	Description	Part Number	Description
2538330	Thrust Washer	2577319	Roller Assembly
367694	Spring Retainer	2577322	Inner Spring Seat/Race
		2577323	Outer Spring Seat/Race
2523757	Spring (7 coils)	2577315	Spring (5 coils)

**C. INSTALLATION:**

1. Remove the lever from the mixture valve lever assembly. Remove the screws, washers, and spacer retaining mixture valve lever assembly and pull it from the servo.
2. Disassemble the mixture valve lever assembly.
3. Measure the length of the idle mixture link from center of pin to center of pin and make note of this dimension. Remove the spring, if installed, from behind the thumb-wheel on the idle mixture linkage. Remove the link from between the throttle and the idle valve lever assembly.
4. Remove the screws and washers retaining idle valve lever assembly and pull it from the servo.
5. Disassemble the idle valve lever assembly.
6. Clean all the parts to be reused.
7. Install new O-rings on the valve shafts and a new seal in the mixture valve bushing.
8. Apply a thin coating of Krytox or Braycote grease to the valve shafts and inside surface of the bushings using a Q-Tip swab. Slide the shafts into the bushings, then withdraw them part way. Wipe away any grease that extruded from between the shafts and bushings. The only grease that is inside the bushing should be left in the assembly. Wipe away excess grease in the bearing cavity (idle bushing) and above the spring seat (mixture bushing). Lubricate the bearing assembly with a drop or two of light oil. Complete assembly of the valves as shown in Figures 1, 2 and 3.

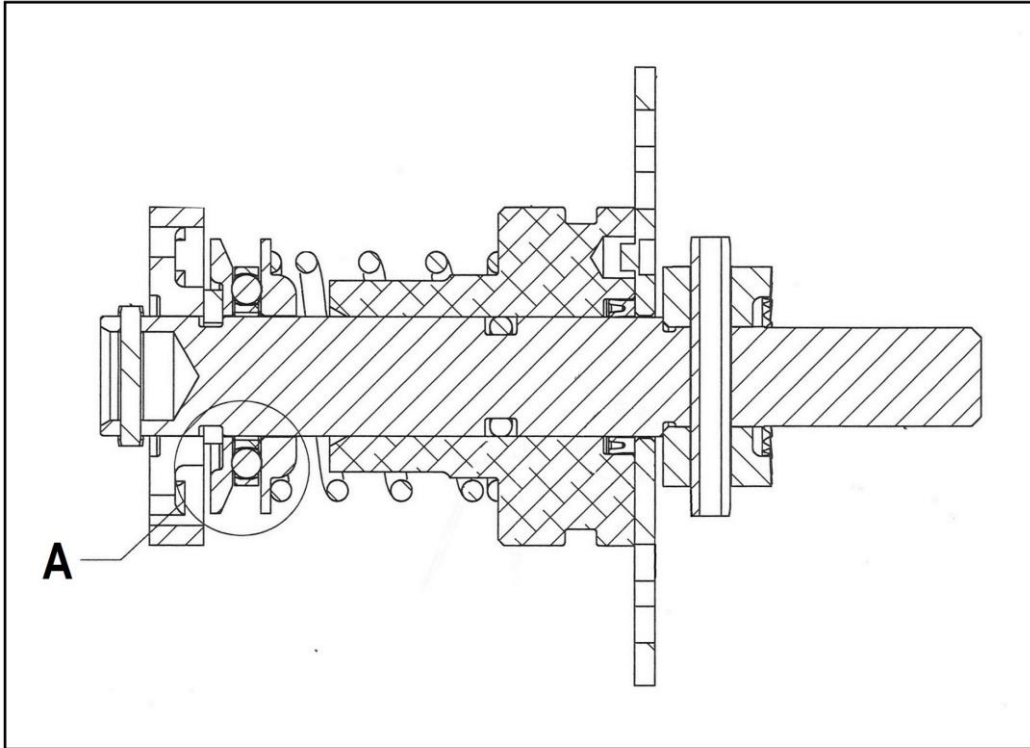

Figure 1, Mixture Valve Lever Assembly

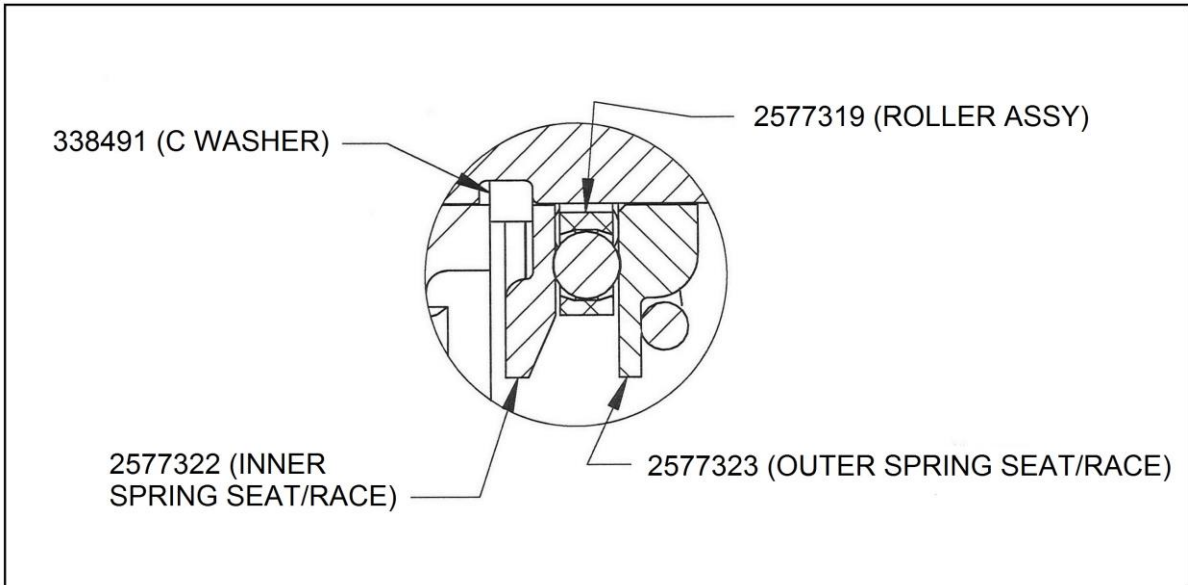

Figure 2, Detail A

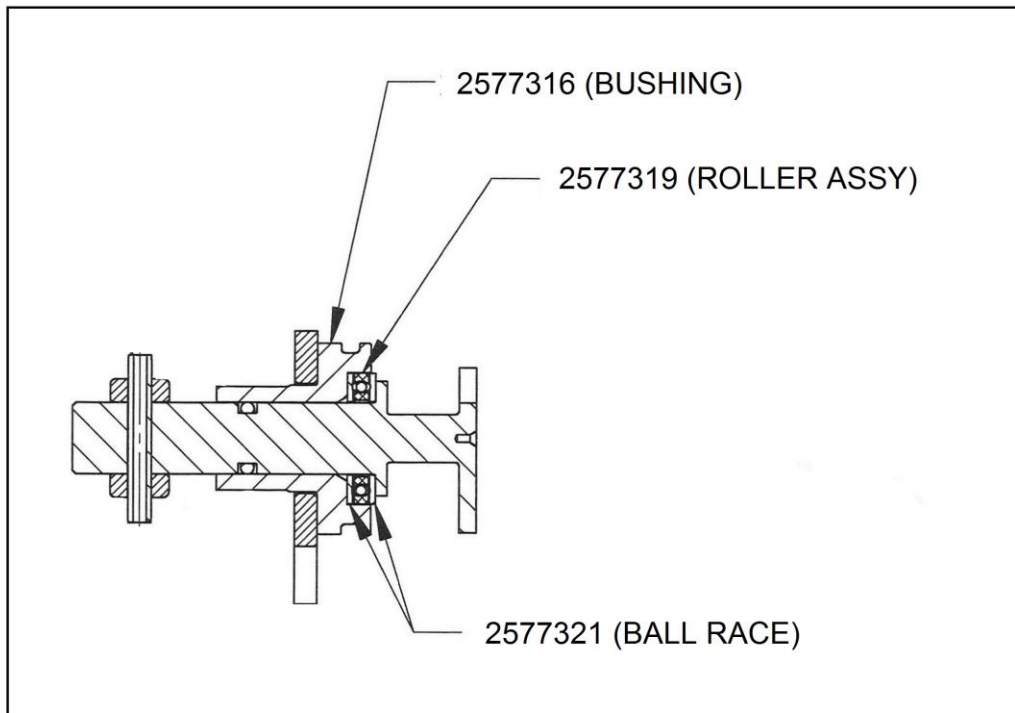

Figure 3, Idle Valve Lever Assembly

9. Install O-rings P/Ns 951400 (idle valve assy.) and 951401 (mixture valve assy.) on the bushings and apply a few drops of light oil to them and to the faces of the valve plates. Install the valve assemblies into the servo per the CMM. Safety wire the screws.
10. Re-install the idle mixture link and thumbwheel spring (if used).
11. After installation of BOTH the idle and mixture valve assemblies with current versions as described in this service bulletin, the repetitive inspections required by Service Bulletin PRS-109 are no longer required.
12. Upon installing the valve kit in the field, the servo data tag must be marked in the upper right quadrant with the letter "B" as shown in the red circle in Figure 4.

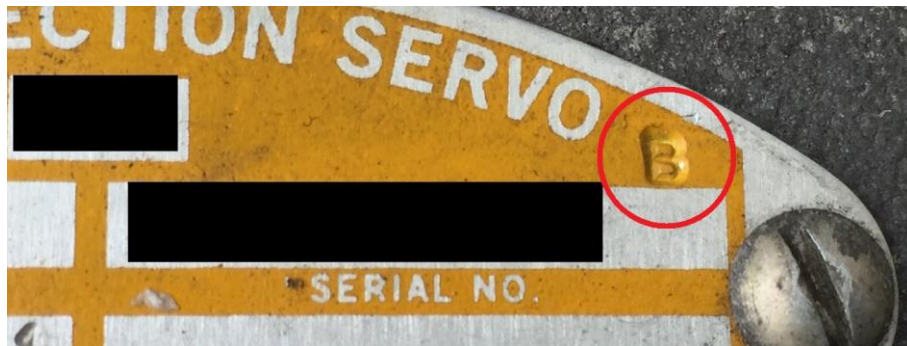

Figure 4

Precision Airmotive Service Bulletin PRS-110

When the installation is accomplished by the manufacturer, Precision Airmotive, the “IC” number, shown on the data tag, in table A or higher number indicates compliance with this bulletin.

<b>Model RSA-5AD1®</b>		
<b>Parts list number</b>	<b>Basic Assembly</b>	<b>I.C. number when incorporated</b>
2524054-11, 2524171-11, 2524189-11, 2524213-11, 2524243-11, 2524341-10, 2524450-9, 2524459-9, 2524550-8, 2524575-8, 2524590-8, 2524592-8, 2524623-8, 2524634-8, 2524673-8, 2524840-3, 2524948-2, 2576558-1, 2524147-13, 2524291-11, 2524297-10, 2576568-1	2524469-N	43
2524145-12, 2524242-10, 2524307-10, 2576524-2	2524472-N	44
2524147-13, 2524291-11, 2524297-10, 2576586-1	2576515-A	43
2524328-10, 2524335-10	2524474-N	45
2524348-11, 2524682-8	2524650-N	32
2524359-11	2524521-N	42
2524742-8, 2524752-7	2524741-L	22
2524905-2	2524904-D	11
2549050-3	2549049-C	7
2576536-2	2576535-A	49
2576544-3, 2576644-1	2576543-B	46
2576592-2	2576591-B	6
2576608-1	2576607-A	4
<b>Model RSA-10ED1®</b>		
2524273-12, 2524298-12, 2524420-11, 2524491-9, 2524534-9, 2524556-9, 2524582-8	2524648-N	39
2524500-9	2524572-P	50
2576562-4	2576561-C	10
<b>Model RSA-10AD1®</b>		
2524163-15	2524510-R	49
2576630-4	2576629-D	9

Table A

13. This configuration and its component parts are covered by patent # US 10215140B2.

**Contact Information:** Precision Airmotive LLC  
 Product Support Department  
 (360) 651-8282  
 www.precisionairmotive.com